



# Frontier Electronics Corp.

667 E. COCHRAN STREET, SIMI VALLEY, CA 93065

TEL: (805) 522-9998 FAX: (805) 522-9989

E-mail: [frontiersales@frontierusa.com](mailto:frontiersales@frontierusa.com)

Web: <http://www.frontierusa.com>

## DUAL SURFACE MOUNT SWITCHING DIODE

### BAV70

#### FEATURES

- FAST SWITCHING
- SURFACE MOUNT PACKAGE IDEALLY SUITED FOR AUTOMATIC INSERTION
- HIGH CONDUCTANCE

#### MECHANICAL DATA

- CASE: SOT-23, PLASTIC, DIMENSIONS IN MILLIMETERS
- TERMINALS: SOLDERABLE PER MIL-STD-202, METHOD 208
- POLARITY: SEE DIAGRAM
- WEIGHT: 0.008 GRAMS

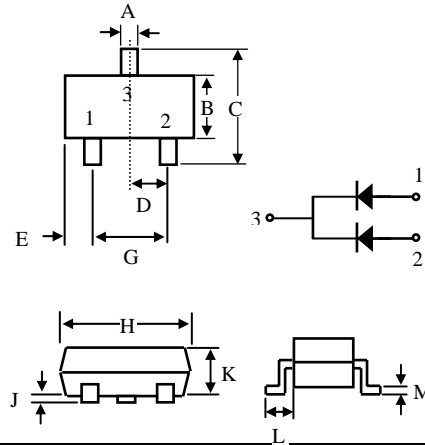

DIM	Min	Max
A	0.30	0.51
B	1.20	1.60
C	2.10	3.00
D	0.85	1.05
E	0.45	1.00
G	1.70	2.10
H	2.70	3.10
J	0.00	0.13
K	0.89	1.30
L	0.30	0.61
M	0.076	0.25

RATINGS	SYMBOL	BAV70	UNITS
PEAK REPETITIVE REVERSE VOLTAGE	$V_{RRM}$		
WORKING PEAK REVERSE VOLTAGE	$V_{RWM}$	70	V
DC BLOCKING VOLTAGE	$V_R$		
FORWARD CONTINUOUS CURRENT (NOTE 1)	$I_{FM}$	300	mAdc
RECTIFIED CURRENT ( AVERAGE ) ,HALF WAVE RECTIFICATION WITH RESIST LOAD AT $T_{amb} = 25^{\circ}C$ AND $\geq 50MHZ$ ( NOTE 1 )	$I_O$	150	mA
NON-REPETITIVE PEAD FORWARD SURGE CURRENT @ $T=1.0\mu s$ @ $T=1.0S$	$I_{FM}$	2.0 1.0	A
TOTAL DEVICE DISSIPATION FR-5 BOARD ( NOTE 2 )	$P_D$	350	mW
DERATE ABOVE 25°C		2.8	mW/°C
THERMAL RESISTANCE JUNCTION TO AMBIENT	$R_{\theta JA}$	357	°C / W
JUNCTION TEMPERATURE	$T_J$	- 55 TO + 150	°C
STORAGE TEMPERATURE RANGE	$T_S$	- 55 TO + 150	°C
MARKING		A4	

#### ELECTRICAL CHARACTERISTICS @ $T_A=25^{\circ}C$ UNLESS OTHERWISE SPECIFIED

CHARACTERISTICS	SYMBOL	Min.	Max.	Unit	Test Condition
MAXIMUM FORWARD VOLTAGE	$V_F$	-	715	mV	$I_F = 1.0$ mA
			855	mV	$I_F = 10$ mA
			1.0	V	$I_F = 50$ mA
			1.25	V	$I_F = 150$ mA
MAXIMUM PEAK REVERSE CURRENT	$I_R$	-	5.0	$\mu$ A	$V_R = 70Vdc$
			60	$\mu$ A	$V_R = 25Vdc, T_J = 150^{\circ}C$
			100	$\mu$ A	$V_R = 70Vdc, T_J = 150^{\circ}C$
CAPACITANCE	$C_J$	-	4	pF	$V_R = 0, f = 1.0MHZ$
REVERSE RECOVERY TIME	$T_{RR}$	-	6.0	nS	$I_F = 10mA$ to $I_{RR} = 1.0$ mA $V_R = 6.0V, R_L = 100\Omega$

NOTE: 1. DIODE ON ALUMINA 10mm×8 mm×0.7mm

# RATING AND CHARACTERISTICS CURVES BAV70

FIG.1 - FORWARD CHARACTERISTICS

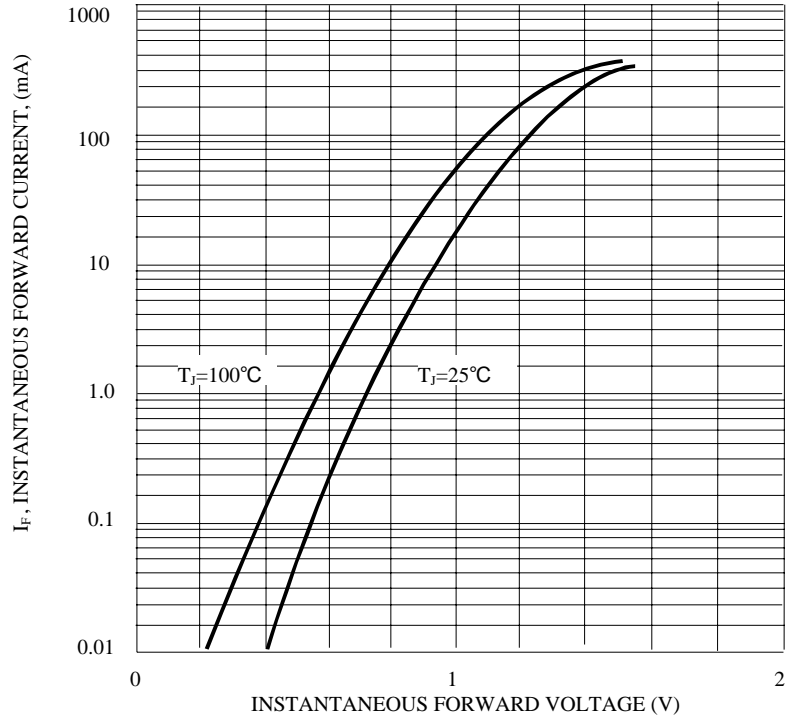

FIG.2- LEAKAGE CURRENT vs JUNCTION TEMPERATURE

