



Frontier Electronics Corp.

667 E. COCHRAN STREET, SIMI VALLEY, CA 93065

TEL: (805) 522-9998 FAX: (805) 522-9989

E-mail: frontiersales@frontierusa.com

Web: <http://www.frontierusa.com>

DUAL SURFACE MOUNT SWITCHING DIODE

BAW56

FEATURES

- FAST SWITCHING
- SURFACE MOUNT PACKAGE IDEALLY SUITED FOR AUTOMATIC INSERTION
- HIGH CONDUCTANCE

MECHANICAL DATA

- CASE: SOT-23, PLASTIC, DIMENSIONS IN MILLIMETERS
- TERMINALS: SOLDERABLE PER MIL-STD-202, METHOD 208
- POLARITY: SEE DIAGRAM
- WEIGHT: 0.008 GRAMS

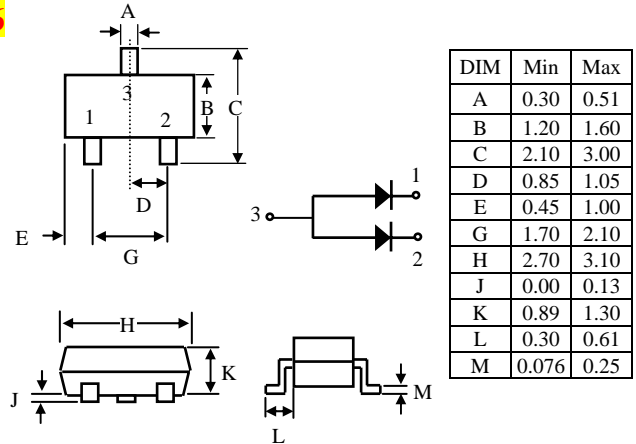

DIM	Min	Max
A	0.30	0.51
B	1.20	1.60
C	2.10	3.00
D	0.85	1.05
E	0.45	1.00
G	1.70	2.10
H	2.70	3.10
J	0.00	0.13
K	0.89	1.30
L	0.30	0.61
M	0.076	0.25

RATINGS	SYMBOL	BAW56	UNITS
PEAK REPETITIVE REVERSE VOLTAGE	V_{RRM}		
WORKING PEAK REVERSE VOLTAGE	V_{RWM}	70	V
DC BLOCKING VOLTAGE	V_R		
FORWARD CONTINUOUS CURRENT (NOTE 1)	I_{FM}	300	mA dc
RECTIFIED CURRENT (AVERAGE) ,HALF WAVE RECTIFICATION WITH RESIST LOAD AT $T_{amb} = 25^{\circ}C$ AND $\geq 50MHZ$ (NOTE 1)	I_O	150	mA
PEAK FORWARD SURGE CURRENT @ $t=1.0 S$ @ $t=1.0 \mu S$	$I_{FM}(surge)$	1.0 2.0	A
TOTAL DEVICE DISSIPATION FR-5 BOARD (NOTE 1) DERATE ABOVE $25^{\circ}C$	P_D	350 2.8	mW mW/ $^{\circ}C$
THERMAL RESISTANCE JUNCTION TO AMBIENT	$R_{\theta JA}$	357	$^{\circ}C / W$
TOTAL DEVICE DISSIPATION ALUMINA SUBSTRATE (NOTE 2) DERATE ABOVE $25^{\circ}C$	P_D	350 2.8	mW mW/ $^{\circ}C$
JUNCTION TEMPERATURE	T_J	- 55 TO + 150	$^{\circ}C$
STORAGE TEMPERATURE RANGE	T_S	- 55 TO + 150	$^{\circ}C$
MARKING		A1	

ELECTRICAL CHARACTERISTICS @ $T_A=25^{\circ}C$ UNLESS OTHERWISE SPECIFIED

CHARACTERISTICS	SYMBOL	Min.	Max.	Unit	Test Condition
MAXIMUM FORWARD VOLTAGE	V_F	-	715	mV	$I_F = 1.0 mA$
			855	mV	$I_F = 10 mA$
			1.0	V	$I_F = 50 mA$
			1.25	V	$I_F = 150 mA$
MAXIMUM PEAK REVERSE CURRENT	I_R	-	2.5	μA	$V_R = 70Vdc$
			50	μA	$V_R = 25Vdc, T_J = 150^{\circ}C$
			100	μA	$V_R = 70Vdc, T_J = 150^{\circ}C$
CAPACITANCE	C_J	-	4.0	pF	$V_R = 0, f = 1.0MHZ$
REVERSE RECOVERY TIME	T_{RR}	-	6.0	nS	$I_F = 10mA$ to $I_{RR} = 1.0 mA$ $V_R = 6.0V, R_L = 100\Omega$

NOTE: 1. DIODE ON ALUMINA 10mm x 8 mm x 0.7mm

RATING AND CHARACTERISTICS CURVES BAW56

FIG.1 - FORWARD CHARACTERISTICS

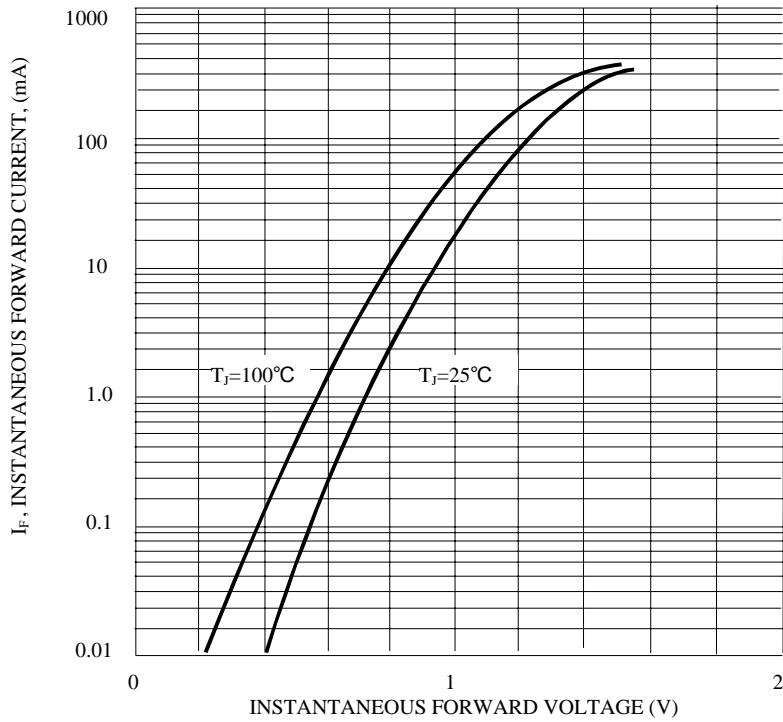

FIG.2- LEAKAGE CURRENT vs

