



# Frontier Electronics Corp.

667 E. COCHRAN STREET, SIMI VALLEY, CA 93065

TEL: (805) 522-9998 FAX: (805) 522-9989

E-mail: [frontiersales@frontierusa.com](mailto:frontiersales@frontierusa.com)

Web: <http://www.frontierusa.com>

## 1A SURFACE MOUNT FAST EFFICIENT RECOVERY RECTIFIERS

### ES1A THRU ES1J

#### FEATURES

- FOR SURFACE MOUNTED APPLICATIONS
- LOW PROFILE PACKAGE
- BUILT-IN STRAIN RELIEF
- EASY PICK AND PLACE
- GLASS PASSIVATED CHIP JUNCTION
- PLASTIC MATERIAL USED CARRIES UNDERWRITERS LABORATORY CLASSIFICATION 94 V-0
- HIGH TEMPERATURE SOLDERING : 250°C/10 SECONDS AT TERMINALS

#### MECHANICAL DATA

- CASE: MOLDED PLASTIC, DO-214AC (SMA), DIMENSIONS IN INCHES AND (MILLIMETERS)
- TERMINALS: SOLDER PLATED
- POLARITY: INDICATED BY CATHODE BAND
- WEIGHT: 0.064 GRAMS

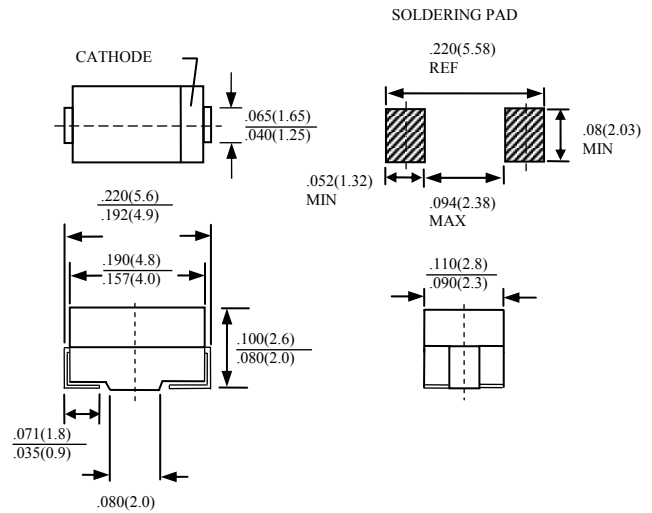

MAXIMUM RATINGS AND ELECTRICAL CHARACTERISTICS RATINGS AT 25°C AMBIENT TEMPERATURE UNLESS OTHERWISE SPECIFIED SINGLE PHASE, HALF WAVE, 60 HZ, RESISTIVE OR INDUCTIVE LOAD. FOR CAPACITIVE LOAD, DERATE CURRENT BY 20%

RATINGS	SYMBOL	ES1A	ES1B	ES1D	ES1E	ES1G	ES1J	UNITS
MAXIMUM RECURRENT PEAK REVERSE VOLTAGE	$V_{RRM}$	50	100	200	300	400	600	V
MAXIMUM RMS VOLTAGE	$V_{RMS}$	35	70	140	210	280	420	V
MAXIMUM DC BLOCKING VOLTAGE	$V_{DC}$	50	100	200	300	400	600	V
MAXIMUM AVERAGE FORWARD RECTIFIED CURRENT AT $T_L=90^\circ\text{C}$	$I_o$	1.0						A
MAXIMUM OVERLOAD SURGE 8.3ms SINGLE HALF SINE-WAVE	$I_{FSM}$	30						A
TYPICAL JUNCTION CAPACITANCE (NOTE 1)	$C_j$	15			10			PF
TYPICAL THERMAL RESISTANCE (NOTE 2)	$\theta_{JL}$	30						$^\circ\text{C}/\text{W}$
STORAGE TEMPERATURE RANGE	$T_{STG}$	-55 TO + 150						$^\circ\text{C}$
OPERATING TEMPERATURE RANGE	$T_{OP}$	-55 TO + 125						$^\circ\text{C}$

#### ELECTRICAL CHARACTERISTICS ( $A_T T_A = 25^\circ\text{C}$ UNLESS OTHERWISE NOTED)

CHARACTERISTICS	SYMBOL	ES1A	ES1B	ES1D	ES1E	ES1G	ES1J	UNITS
MAXIMUM FORWARD VOLTAGE AT 1.0A AND 25°C	$V_F$	0.98			1.25		1.75	V
MAXIMUM REVERSE CURRENT AT 25°C	$I_R$	10						$\mu\text{A}$
MAXIMUM REVERSE RECOVERY TIME (NOTE 3)	$T_{RR}$	25						nS
MARKING		ES1A	ES1B	ES1D	ES1E	ES1G	ES1J	

NOTE: 1. MEASURED AT 1.0 MHZ AND APPLIED REVERSE VOLTAGE OF 4.0 V

2. THERMAL RESISTANCE FROM JUNCTION TO TERMINAL  $5.0\text{mm}^2$  (.013 mm THICK) LAND AREAS

3. REVERSE RECOVERY TEST CONDITIONS:  $I_F=0.5\text{A}$ ,  $I_R=1.0\text{A}$ ,  $I_{RR}=0.25\text{A}$

# RATINGS AND CHARACTERISTIC CURVE ES1A THRU ES1J

FIG. 1-TEST CIRCUIT DIAGRAM AND REVERSE RECOVERY TIME CHARACTERISTIC

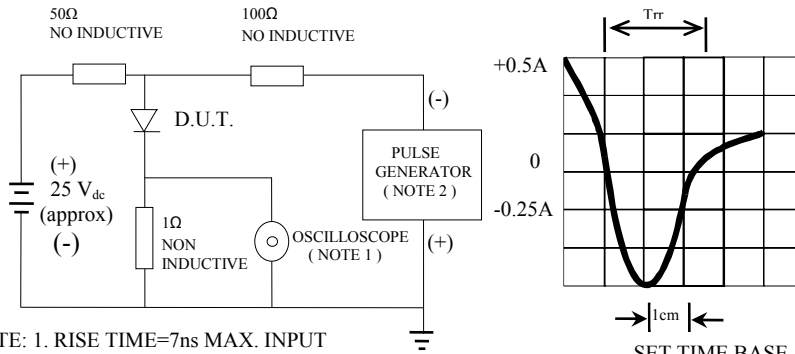

NOTE: 1. RISE TIME=7ns MAX. INPUT IMPEDANCE=1 MOhms 22PF  
2. RISE TIME =10ns MAX. SOURCE IMPEDANCE=50 OHMS

FIG. 2-TYPICAL FORWARD CURRENT DERATING CURVE

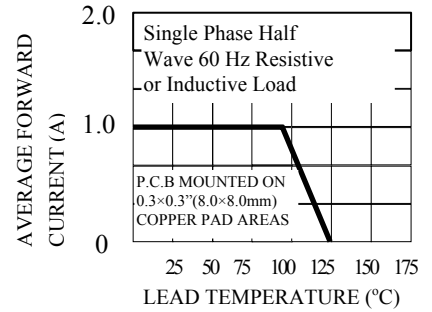

REVERSE CHARACTERISTICS

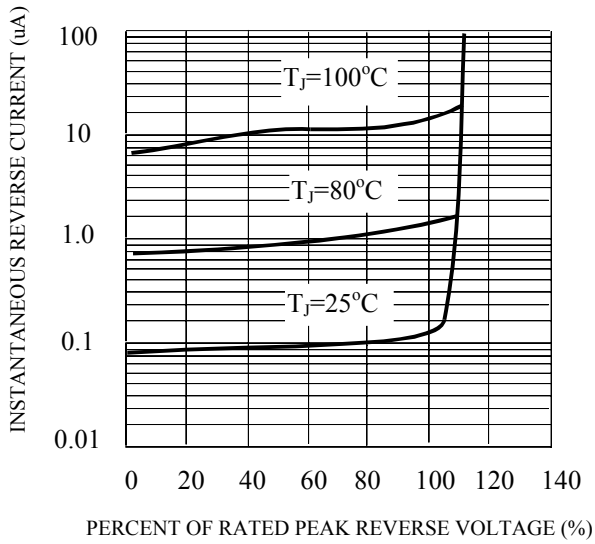

FIG. 4-TYPICAL INSTANTANEOUS FORWARD CHARACTERISTICS

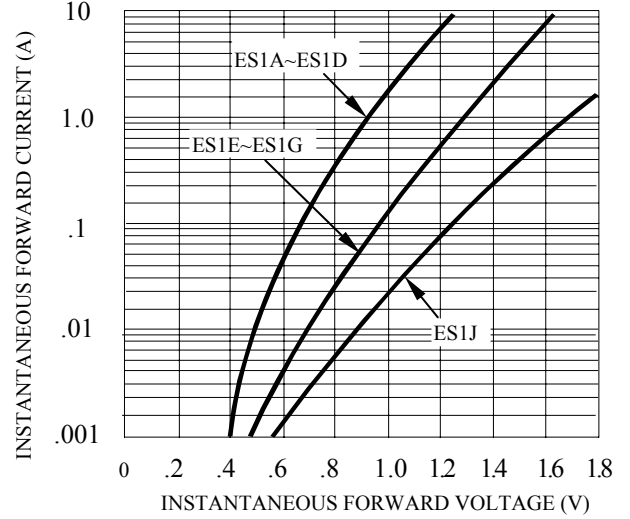

FIG. 5-MAXIMUM NON-REPETITIVE FORWARD SURGE CURRENT

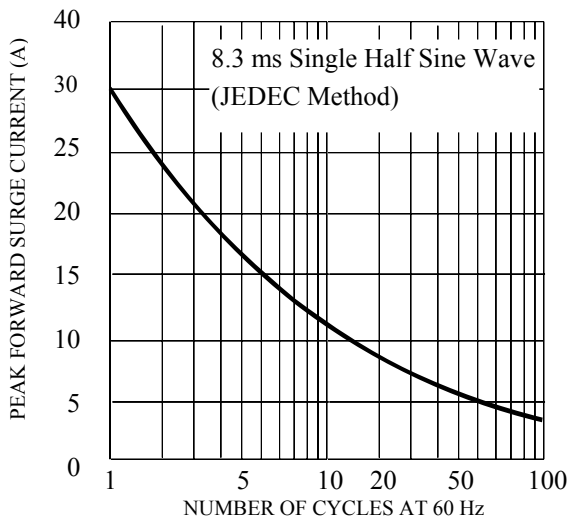

FIG. 6-TYPICAL JUNCTION CAPACITANCE

