



# Frontier Electronics Corp.

667 E. COCHRAN STREET, SIMI VALLEY, CA 93065

TEL: (805) 522-9998 FAX: (805) 522-9989

E-mail: [frontiersales@frontierusa.com](mailto:frontiersales@frontierusa.com)

Web: <http://www.frontierusa.com>

## 1A SURFACE MOUNT FAST RECOVERY RECTIFIERS

### FFM101M THRU FFM107M

#### FEATURES

- FOR SURFACE MOUNTED APPLICATIONS
- LOW PROFILE PACKAGE
- BUILT-IN STRAIN RELIEF
- EASY PICK AND PLACE
- PLASTIC MATERIAL USED CARRIES UNDERWRITERS LABORATORY CLASSIFICATION 94 V-0
- FAST SWITCHING
- HIGH TEMPERATURE SOLDERING 250°C/10 SECONDS AT TERMINALS

#### MECHANICAL DATA

- CASE: MOLDED PLASTIC, SOD-123, DIMENSIONS IN INCHES AND (MILLIMETERS)
- TERMINALS: SOLDER PLATED
- POLARITY: INDICATED BY CATHODE BAND
- WEIGHT: 0.04 GRAMS

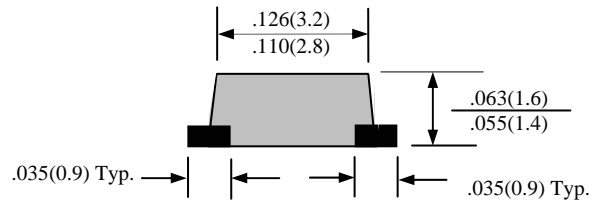
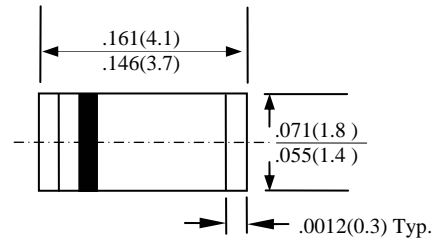

MAXIMUM RATINGS AND ELECTRICAL CHARACTERISTICS RATINGS AT 25°C AMBIENT TEMPERATURE UNLESS OTHERWISE SPECIFIED SINGLE PHASE, HALF WAVE, 60 HZ, RESISTIVE OR INDUCTIVE LOAD. FOR CAPACITIVE LOAD, DERATE CURRENT BY 20%

RATINGS	SYMBOL	FFM101M	FFM102M	FFM103M	FFM104M	FFM105M	FFM106M	FFM107M	UNITS
MAXIMUM RECURRENT PEAK REVERSE VOLTAGE	$V_{RRM}$	50	100	200	400	600	800	1000	V
MAXIMUM RMS VOLTAGE	$V_{RMS}$	35	70	140	280	420	560	700	V
MAXIMUM DC BLOCKING VOLTAGE	$V_{DC}$	50	100	200	400	600	800	1000	V
MAXIMUM AVERAGE FORWARD RECTIFIED CURRENT AT $T_i=90^\circ\text{C}$	$I_O$	1.0							A
MAXIMUM OVERLOAD SURGE 8.3ms SINGLE HALF SINE-WAVE	$I_{FSM}$	30							A
TYPICAL JUNCTION CAPACITANCE (NOTE 1)	$C_j$	15							PF
TYPICAL THERMAL RESISTANCE (NOTE 2)	$\theta_{jL}$	30							°C/W
STORAGE TEMPERATURE RANGE	$T_{STG}$	-55 TO + 150							°C
OPERATING TEMPERATURE RANGE	$T_{OP}$	-55 TO + 125							°C

#### ELECTRICAL CHARACTERISTICS ( $A_T T_A = 25^\circ\text{C}$ UNLESS OTHERWISE NOTED)

CHARACTERISTICS	SYMBOL	FFM101M	FFM102M	FFM103M	FFM104M	FFM105M	FFM106M	FFM107M	UNITS
MAXIMUM FORWARD VOLTAGE AT 1.0A AND 25°C	$V_F$	1.3							V
MAXIMUM REVERSE CURRENT AT 25°C	$I_R$	5							$\mu\text{A}$
MAXIMUM REVERSE RECOVERY TIME (NOTE 3)	$T_{RR}$	150			250		500		nS
MARKING		F1	F2	F3	F4	F5	F6	F7	

- NOTE: 1. MEASURED AT 1.0 MHZ AND APPLIED REVERSE VOLTAGE OF 4.0 V  
 2. THERMAL RESISTANCE FROM JUNCTION TO TERMINAL 5.0mm<sup>2</sup> (.013 mm THICK) LAND AREAS  
 3. REVERSE RECOVERY TEST CONDITIONS:  $I_F=0.5\text{A}$ ,  $I_R=1.0\text{A}$ ,  $I_{RR}=0.25\text{A}$

# RATINGS AND CHARACTERISTIC CURVE FFM101M THRU FFM107M

FIG. 1-TEST CIRCUIT DIAGRAM AND REVERSE RECOVERY TIME CHARACTERISTIC

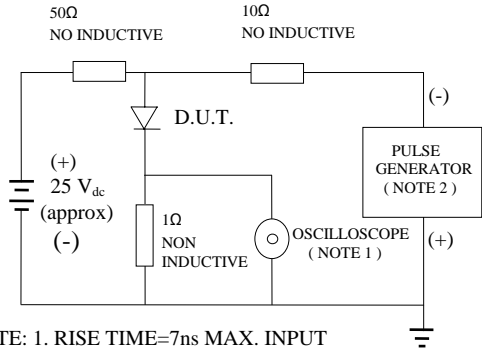

NOTE: 1. RISE TIME=7ns MAX. INPUT IMPEDANCE=1 MOhms 22PF  
2. RISE TIME =10ns MAX. SOURCE IMPEDANCE=50 OHMS

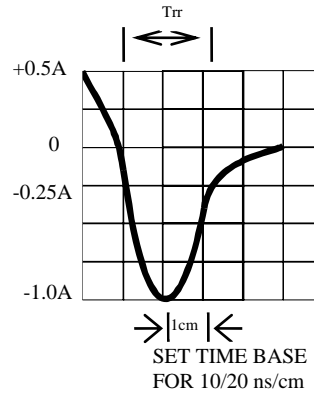

FIG. 2-MAXIMUM CURRENT DERATING CURVE

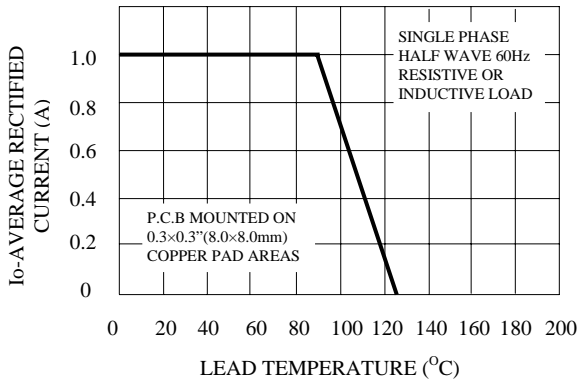

Fig. 5-MAXIMUM FORWARD SURGE CURRENT

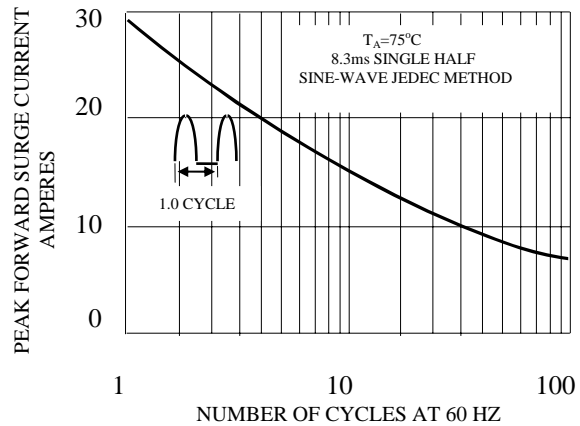

FIG. 3-TYPICAL JUNCTION CAPACITANCE

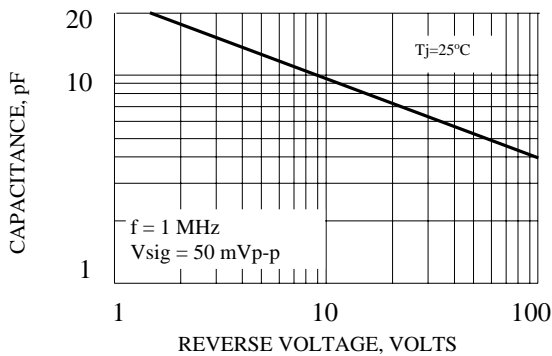

FIG. 4-TYPICAL REVERSE CHARACTERISTICS

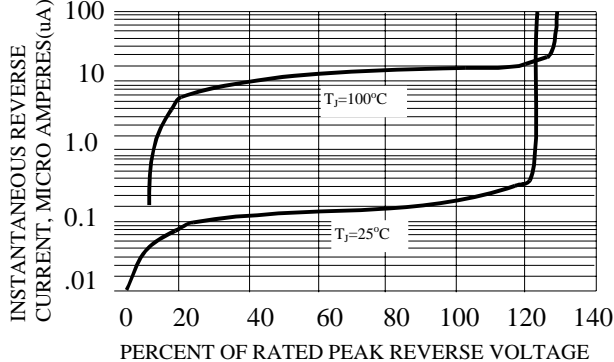

FIG. 6-TYPICAL INSTANTANEOUS FORWARD CHARACTERISTICS

